

# **INSTRUCTION BOOK**

**Model 4400**

# IMPORTANT SAFETY INSTRUCTIONS

When using an electrical appliance, basic safety precautions should always be followed, including the followings:

Read all instructions before using this appliance.

## **DANGER** — To reduce the risk of electric shock:

1. An appliance should never be left unattended when plugged in. Always unplug this sewing machine from the electric outlet immediately after using and before cleaning.
2. Always unplug before replacing a sewing machine bulb. Replace bulb with same type rated 15 Watts.

## **WARNING** — To reduce the risk of burns, fire, electric shock, or injury to persons:

1. Do not allow to be used as a toy. Close attention is necessary when this sewing machine is used by or near children.
2. Use this appliance only for its intended use as described in this owner's manual.  
Use only attachments recommended by the manufacturer as contained in this owner's manual.
3. Never operate this sewing machine if it has a damaged cord or plug, if it is not working properly, if it has been dropped or damaged, or dropped into water.  
Return this sewing machine to the nearest authorized dealers or service center for examination, repair, electrical or mechanical adjustment.
4. Never operate the appliance with any air opening blocked. Keep ventilation openings of this sewing machine and foot controller free from accumulation of lint, dust and loose cloth.
5. Never drop or insert any object into any opening.
6. Do not use outdoors.
7. Do not operate where aerosol (spray) products are being used or where oxygen is being administered.
8. To disconnect, turn all controls to the off ("0") position, then remove plug from outlet.
9. Do not unplug by pulling on cord. To unplug, grasp the plug, not the cord.
10. Keep fingers away from all moving parts. Special care is required around the sewing machine needle.
11. Always use the proper needle plate. The wrong plate can cause the needle to break.
12. Do not use bent needles.
13. Do not pull or push fabric while stitching. It may deflect the needle causing it to break.
14. Switch this sewing machine off ("0") when making any adjustment in the needle area, such as threading the needle, changing the needle, threading the bobbin or changing the presser foot, and the like.
15. Always unplug this sewing machine from the electrical outlet when removing covers, lubricating, or when making any other adjustments mentioned in this owner's manual.

## **SAVE THESE INSTRUCTIONS**

# TABLE OF CONTENTS

## SECTION 1. ESSENTIAL PARTS

Name of Parts .....	2
---------------------	---

## SECTION 2. GETTING READY TO SEW

Extension Table .....	3
Accessories Storage Box .....	3
Standard Accessories .....	3
Connecting the Machine to the Power Supply .....	4
Foot control .....	4
To Attach and Remove the Presser Foot .....	4
Changing Needle .....	5
To check the needle .....	5
Thread and Needle Chart .....	5
Setting Spool Pins .....	6
Removing or Inserting the Bobbin Case .....	6
Winding the Bobbin .....	7
Threading Bobbin Case .....	7
Threading the Machine .....	8
Drawing Up Bobbin Thread .....	9
Balancing Needle Thread Tension .....	10
Adjusting Bobbin Thread Tension .....	10
Pattern Selector Dial .....	11
Stitch Length Dial .....	11
Reverse Stitch Button .....	12
Seam Guide Line .....	12
Darning Plate .....	12

## SECTION 3. BASIC SEWING

Straight Stitch Sewing .....	13
Zigzag Stitching .....	14

## SECTION 4. UTILITY STITCHING

Overcasting .....	14
Overedge Stitching .....	15
Tricot Stitch .....	15
Triple Stitch .....	16
Sewing Buttons .....	17
Buttonhole .....	18
Zipper Application .....	19
Blind Hem Stitch .....	20
Rolled Hem .....	21
Shell Tuck .....	22
Stretch Stitch Patterns .....	22
Smocking .....	23

## SECTION 5. CARE OF YOUR MACHINE

Sewing Light .....	24
Dismantling and Assembling Shuttle Race Unit .....	24
Cleaning the Feed Dog .....	25
Oiling the Machine .....	25
Troubleshooting .....	26

## SECTION 1. ESSENTIAL PARTS

### Name of Parts

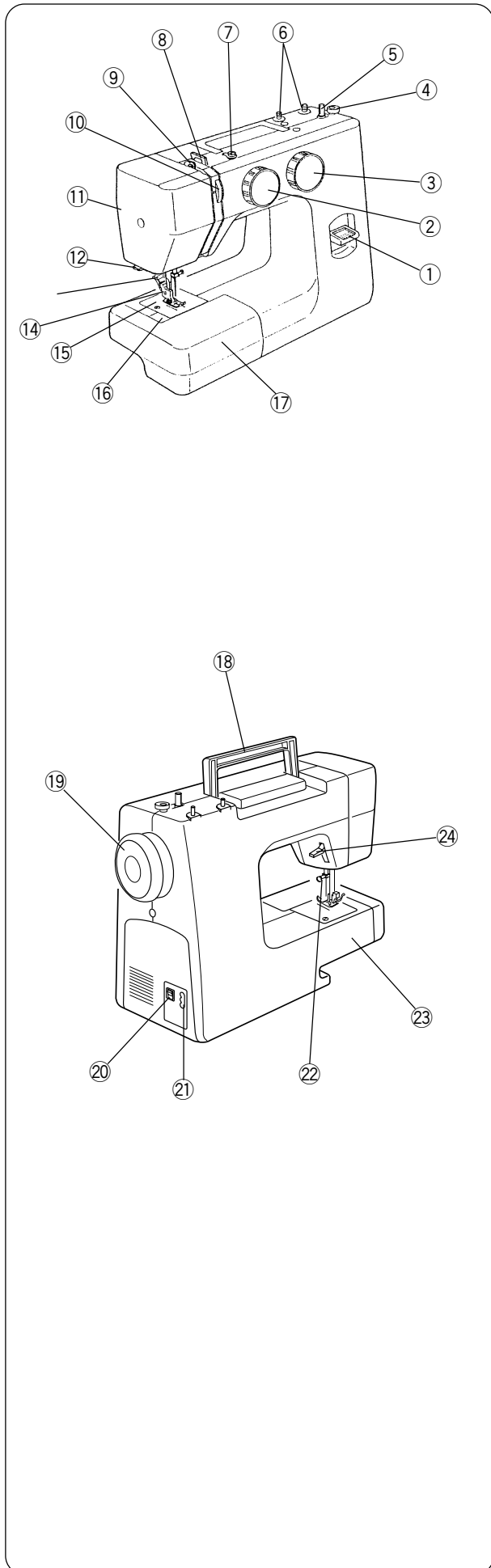

- ① Reverse stitch button
- ② Pattern selector dial
- ③ Stitch length dial
- ④ Bobbin winder stopper
- ⑤ Bobbin winder spindle
- ⑥ Spool pins
- ⑦ Bobbin winder thread guide
- ⑧ Thread guide
- ⑨ Thread take-up lever
- ⑩ Thread tension dial
- ⑪ Face plate
- ⑫ Thread cutter
  
- ⑭ Presser foot holder
- ⑮ Needle plate
- ⑯ Hook cover
- ⑰ Extension table
- ⑱ Carrying handle
- ⑲ Balance wheel
- ⑳ Power switch
- ㉑ Cord socket
- ㉒ Needle clamp screw
- ㉓ Free arm
- ㉔ Presser foot lifter

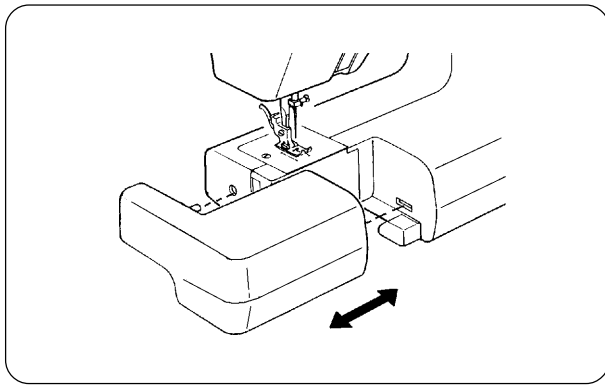

## SECTION 2. GETTING READY TO SEW

### Extension Table

The extension table provides added sewing surface and can be easily removed for free arm sewing.

#### Detaching the table:

Pull the table away from the machine.

#### Attaching the table:

Push the extension table until it snaps into the machine.

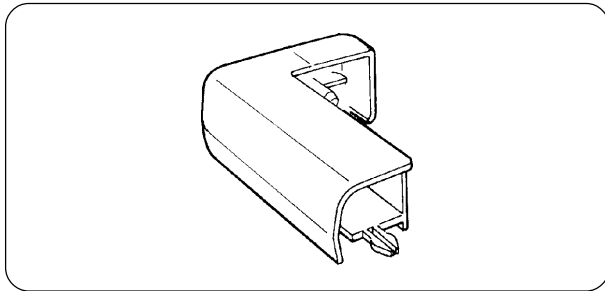

### Accessories Storage Box

Sewing accessories are conveniently located in the extension table.

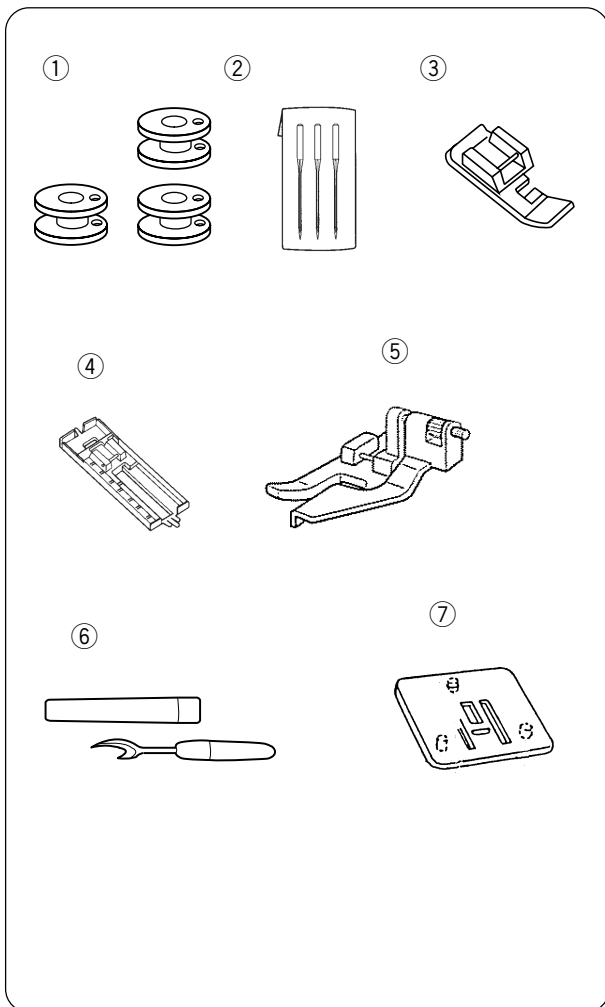

### Standard Accessories

- ① Bobbins
- ② 3 Needles set
- ③ Zipper foot
- ④ Buttonhole foot
- ⑤ Hem guide
- ⑥ Seam ripper/ Buttonhole opener
- ⑦ Darning plate

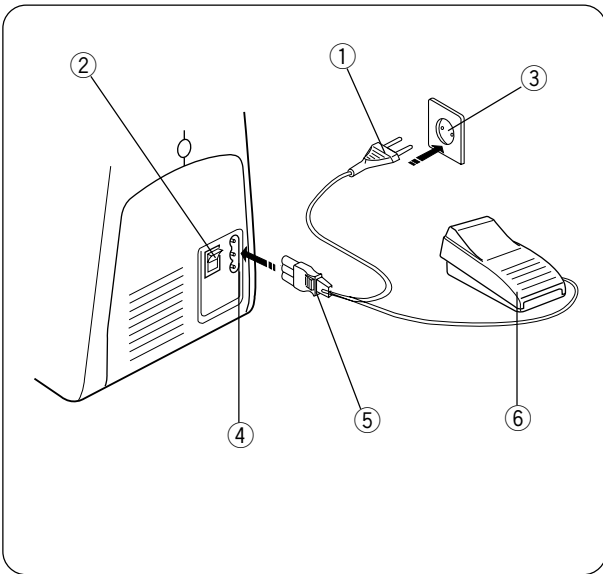

## Connecting the Machine to the Power Supply

Before connecting the power cord, make sure the voltage and frequency shown on the machine conform to your electrical power.

1. Turn off the power switch.
2. Insert the machine plug into the machine socket.
3. Insert the power supply plug into the outlet .
4. Turn on the power switch to turn on the power and sewing light.

- ① Power supply plug
- ② Power switch
- ③ Outlet
- ④ Machine socket
- ⑤ Machine plug
- ⑥ Foot control

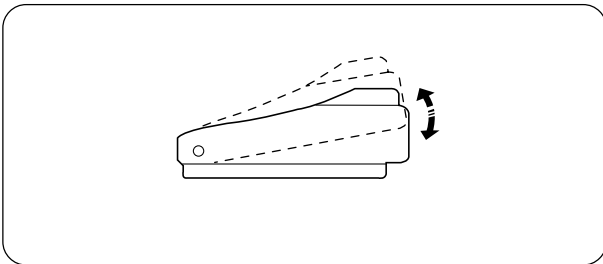

## Foot control

Sewing speed can be varied by the foot control. The harder you press on the control, the faster the machine runs.

### Caution:

Do not place anything on the foot control, otherwise the machine will start advertently.

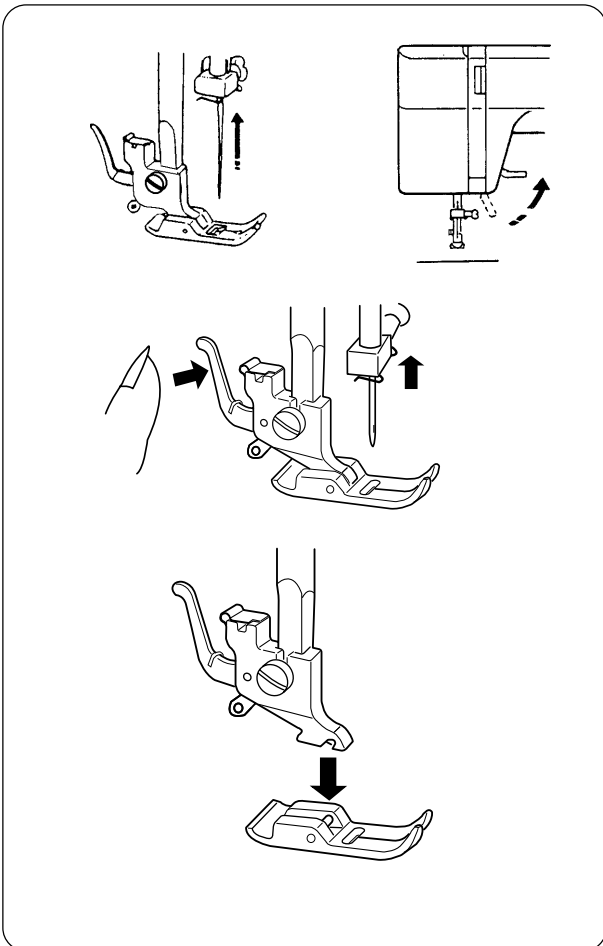

## To Attach and Remove the Presser Foot

### To remove

Turn the handwheel toward you to raise the needle to its highest position.  
Raise the presser foot.

Press the lever on the back of the foot holder.  
The presser foot will drop off.

### To attach

Place the presser foot so the pin on the foot lies just under the groove of the foot holder.  
Lower the foot holder to lock the foot in place.

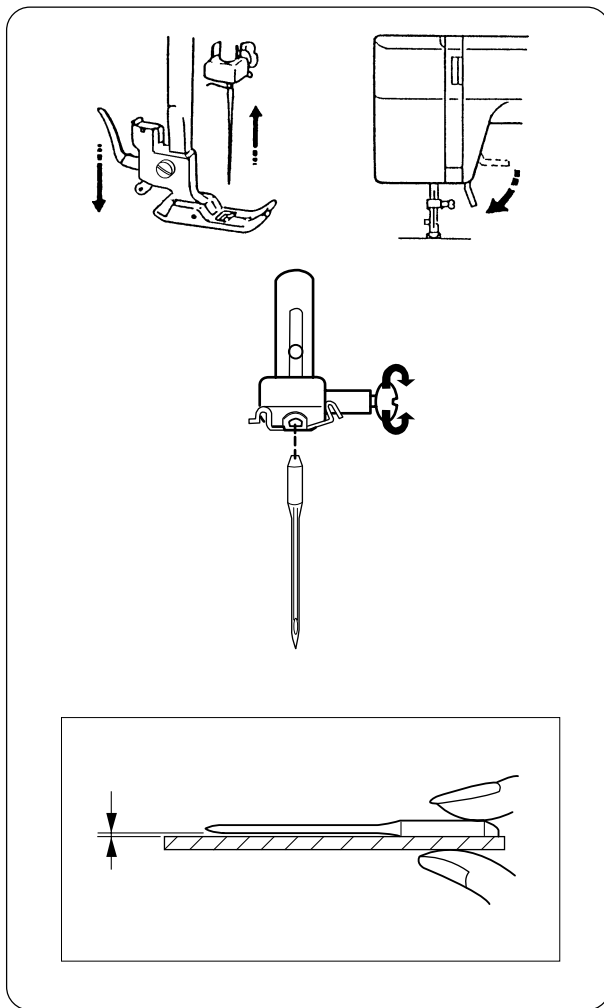

## Changing Needle

Raise the needle by turning the handwheel toward you and lower the presser foot.

Loosen the needle clamp screw by turning it counterclockwise.

Remove the needle from the clamp.

Insert the new needle into the clamp with the flat side away from you.

When inserting the needle into the clamp, push it up as far as it will go and tighten the clamp screw firmly with the screwdriver.

\* Check your needles frequently for barbed or blunted points. Snags and runs in knits, fine silks and silk-like fabrics are permanent and are almost always caused by a damaged needle.

## To check the needle

Place the flat side of the needle on something flat (needle plate, glass etc.). The clearance between the needle and flat surface should be consistent. Never use a bent or blunt needle.

	Fabrics	Thread	Needle Size
<b>Light weight</b>	Crepe de Chine, Voile, Lawn, Organdy, Georgette, Tricot	Fine Silk Fine Cotton Fine Synthetic Fine Cotton Covered Polyester	9 or 11
<b>Medium weight</b>	Linens, Cotton, Pique, Serge, Double Knits, Percale	50 silk 50 to 80 Cotton 50 to 60 Synthetic Cotton Covered Polyester	11 or 14
<b>Heavy weight</b>	Denim, Tweed, Gabardine, Coating, Drapery and Upholstery Fabric	50 silk 40 to 50 Cotton 40 to 50 Synthetic Cotton Covered Polyester	14 16

## Thread and Needle Chart

\* In general, fine threads and needles are used for sewing thin fabrics, and thicker threads and needles are used for sewing heavy fabrics. Always test thread and needle size on a small piece of fabric which will be used for actual sewing.

\* Use the same thread for needle and bobbin.

\* When sewing stretch, very fine fabrics and synthetics, use a BLUE TIPPED needle. The blue tipped needle effectively prevents skipped stitches.

\* When sewing very fine fabrics, sew over a piece of paper Setting Spool Pins The spool pins are used for holding the spool of thread in order to feed thread to the machine.

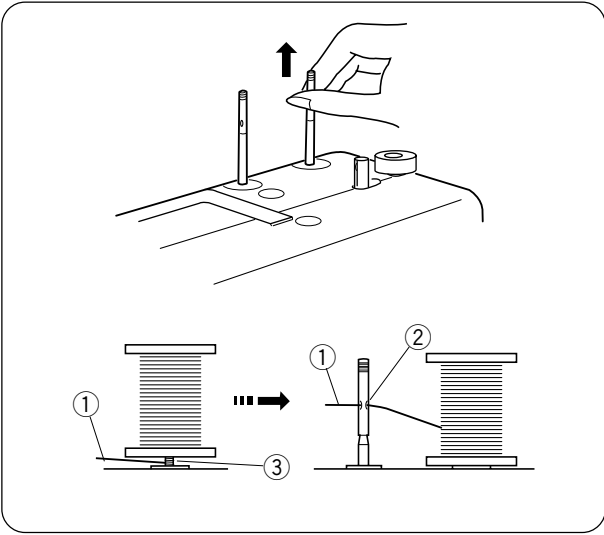

### Setting Spool Pins

The spool pins are used for holding the spool of thread in order to feed thread to the machine. To use, pull up the spool pin. Push down for storage.

- ① Upper thread
- ② Hole
- ③ Tangle

**Note :** When using thread which has tendency to tangle around spool pin, thread through the hole of spool pin as shown. The hole should face the thread spool.

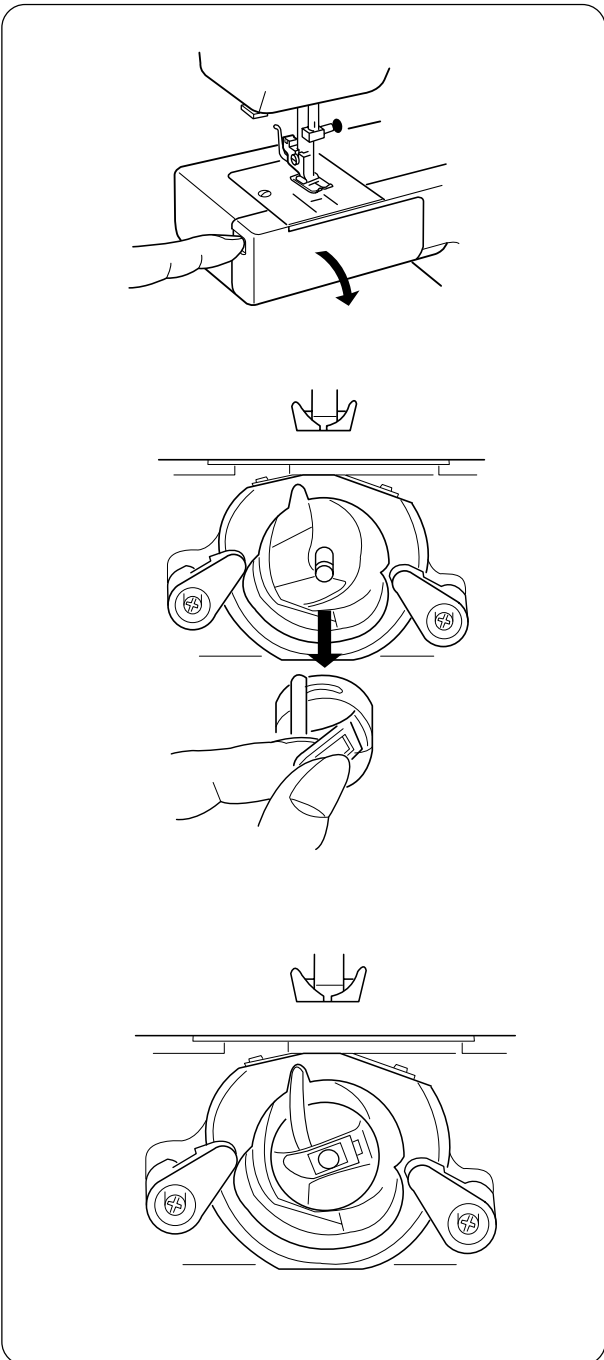

### Removing or Inserting the Bobbin Case

Open the hook cover.

Raise the needle by turning the handwheel toward you.  
Take out the bobbin case by holding the latch.

When inserting the bobbin case, place the horn into the recess of the hook race.



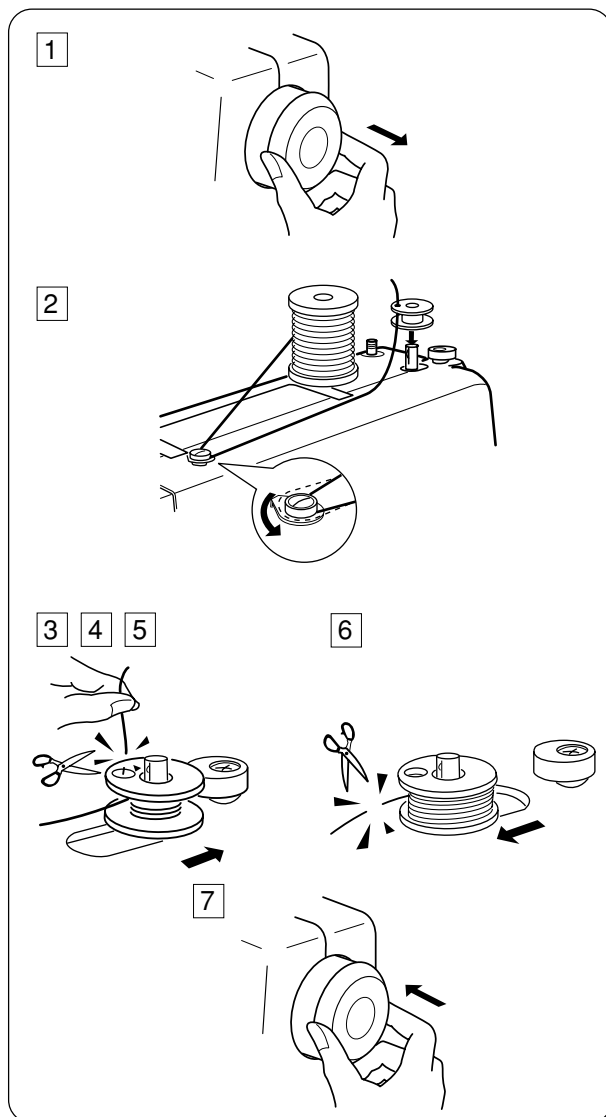

## Winding the Bobbin

- 1 Pull the handwheel out.
- 2 Draw the thread from spool.  
Guide the thread around the bobbin winder thread guide.
- 3 Insert the thread through the hole in the bobbin from the inside to the outside.  
Put the bobbin on the bobbin winder spindle.
- 4 Push it to the right.
- 5 With the free end of the thread held in your hand, depress the foot control.  
Stop the machine when it has made a few turns, and cut the thread close to the hole in the bobbin.
- 6 Depress the foot control again.  
When the bobbin is fully wound, stop the machine.  
Return the bobbin winder spindle to its original position by moving the spindle to the left, and cut the thread.
- 7 Push the handwheel to the left. (original position).

### Note:

Return the bobbin winder spindle when the machine stops.

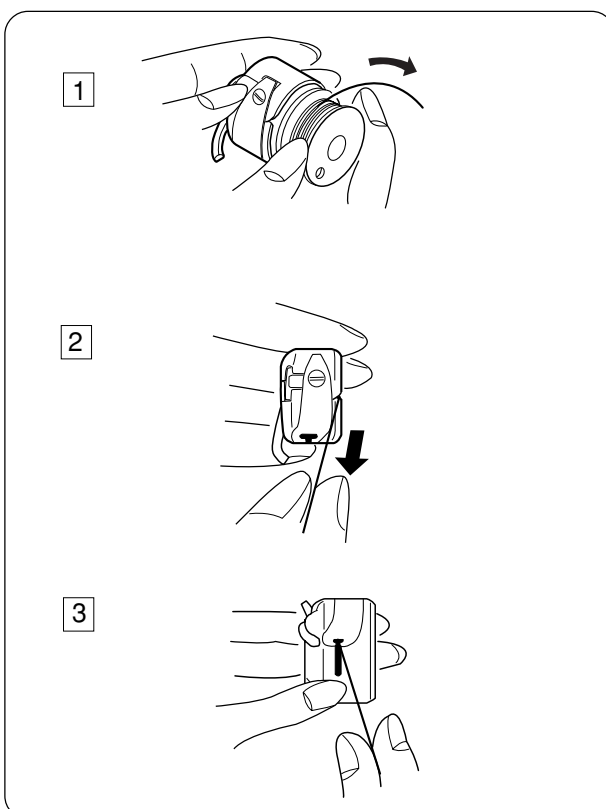

## Threading Bobbin Case

- 1 Place the bobbin into the bobbin case.  
Make sure the thread unwinds in the direction of arrow.
- 2 Pull the thread into the bobbin case slot.
- 3 Draw the thread under the tension spring and into the delivery eye.

\* Leave about 10 cm (4") of free thread.

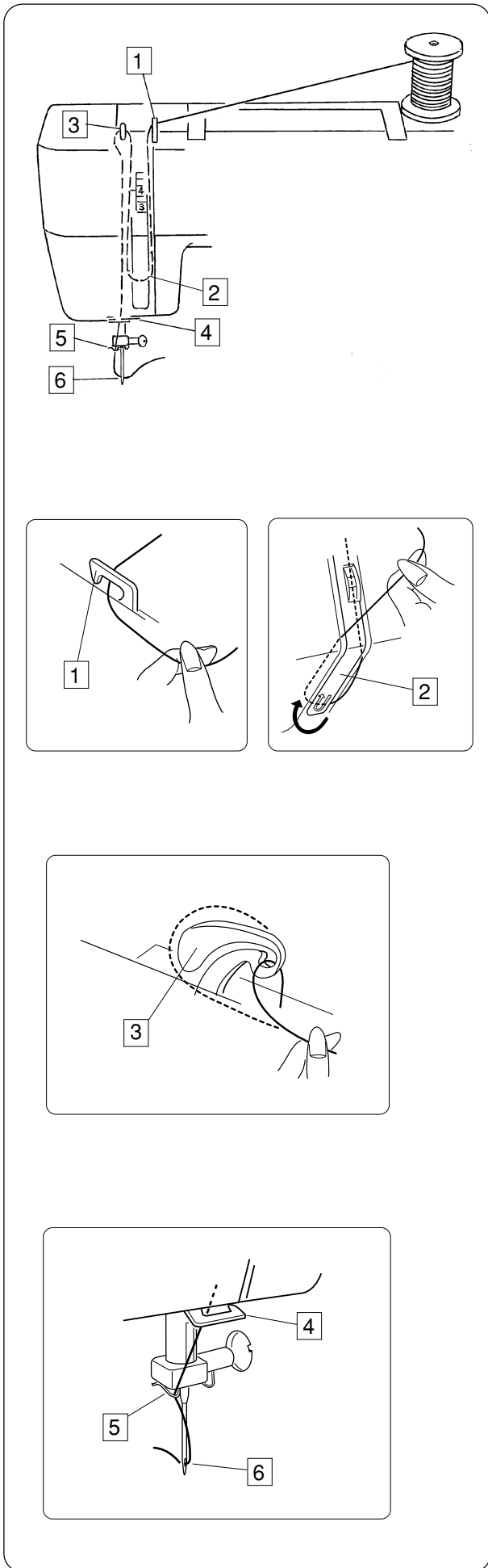

## Threading the Machine

Raise the take-up lever to its highest position by turning the handwheel toward you.

Raise the presser foot.

Place a spool on the spool pin as shown, with thread coming from back of the spool.

**1** Draw the thread into thread guide using both hands.

**2** While holding the thread near spool, draw thread down into the tension area and then around the check spring holder.

**3** Firmly draw the thread up and through the take-up lever from right to left.

**4** Then draw the thread down and slip it into the lower thread guide.

**5** Draw the thread down and slip it into needle bar thread guide on the left.

**6** Thread the needle eye from front to back.

\* Refer to page 10 for the built-in needle threader.

**Note:** You may want to cut the end of thread with sharp scissors for easier needle threading.

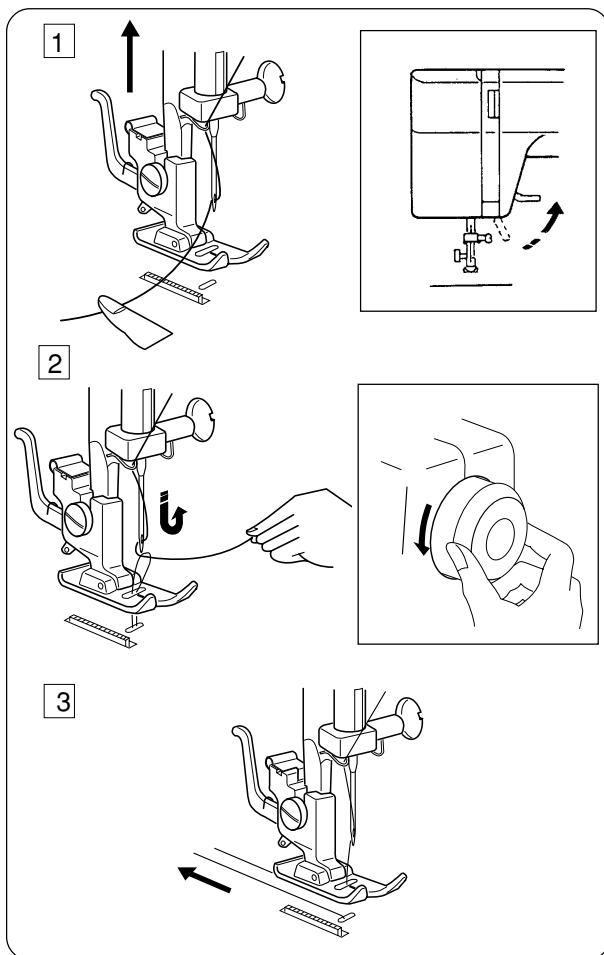

### Drawing Up Bobbin Thread

- 1 Raise the presser foot and hold the needle thread lightly with your left hand.
- 2 Turn the handwheel slowly toward you with your right hand until the needle goes down and continue turning the handwheel until the take-up lever is at its highest position. Lightly draw up the needle thread forming a loop of the bobbin thread.
- 3 Pull 15 cm (6") of both threads back and under the presser foot.

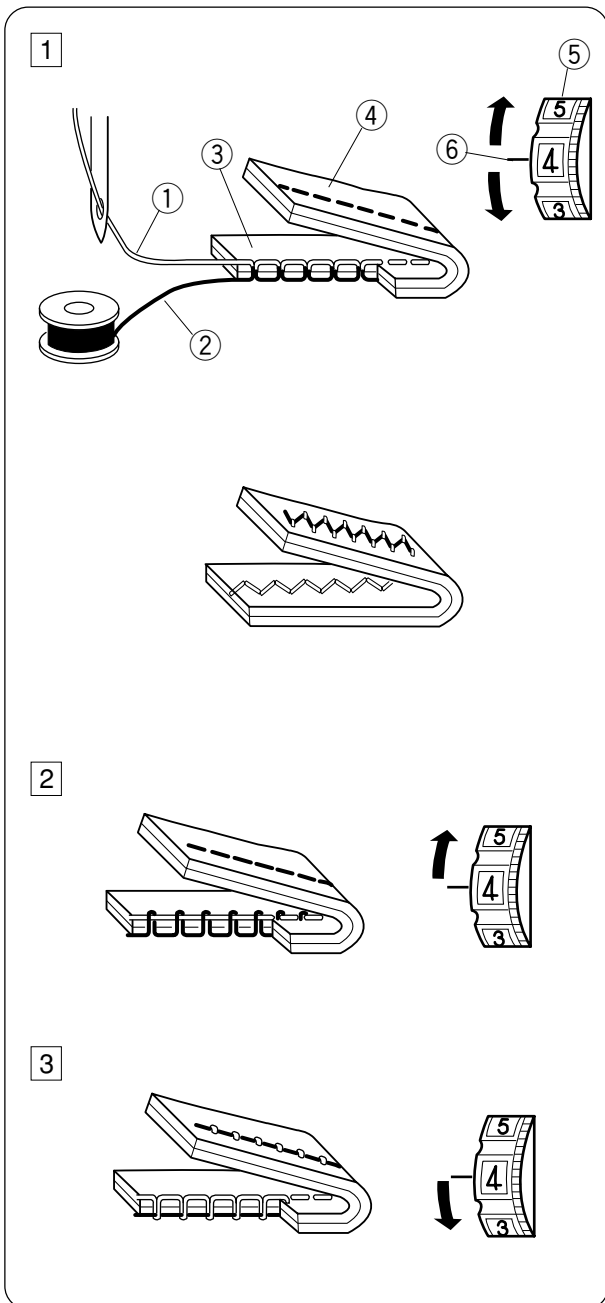

## Balancing Needle Thread Tension

### 1 Correct tension

The thread tension is adjusted depending on the sewing materials, layers of fabric and sewing method.

- \* The ideal straight stitch has threads looked between two layers of fabric, as illustrated (magnifies to show detail).
- \* For an ideal zigzag stitch, the bobbin thread does not show on the right side (top side) of the fabric, and the needle thread shows slightly on the wrong side (bottomside) of the fabric.

- ① Needle thread (Top thread)
- ② Bobbin thread (Bottom thread)
- ③ Right side (Top side) of fabric
- ④ Wrong side (Bottom side) of fabric
- ⑤ Thread tension dial
- ⑥ Setting mark

### 2 Needle thread tension is too tight

When the bobbin thread (bottom thread) will appear on the right side (top side) of the fabric, Loosen the needle thread tension by moving the dial to a lower number.

### 3 Needle thread tension is too loose

When the needle thread (top thread) will appear on the wrong side (bottom side) of the fabric, tighten the needle thread tension by moving the dial to a higher number.

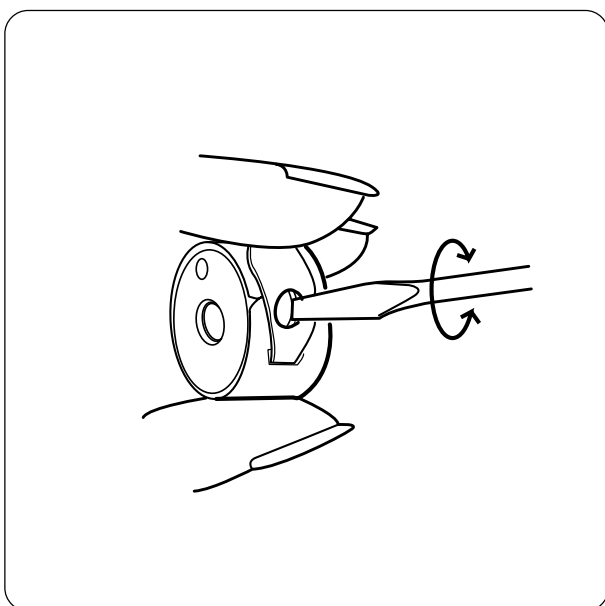

## Adjusting Bobbin Thread Tension

For general sewing, the bobbin thread tension does not need to adjust. However, you can adjust the bobbin thread tension for a specific sewing need.

Turn the adjusting screw to the right to tighten or, to the left to loosen the tension.

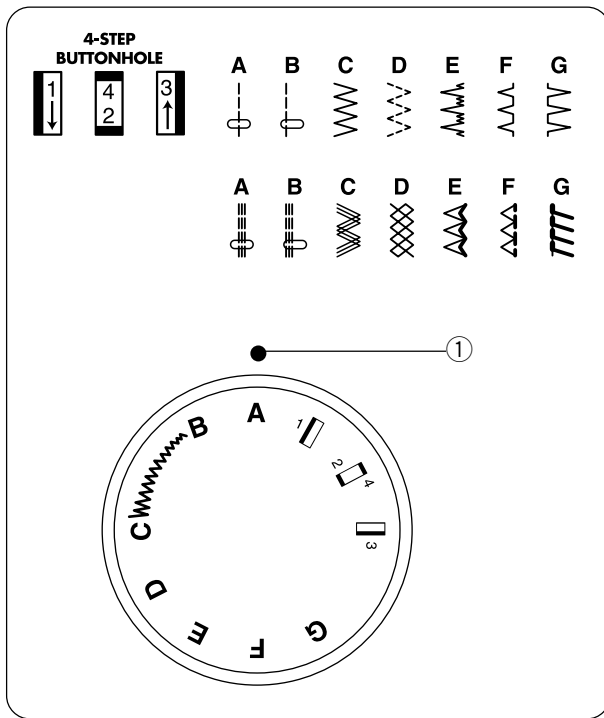

### Pattern Selector Dial

Raise the needle and presser foot. Turn the pattern selector dial to set the symbol corresponding to the desired pattern at the setting mark.

- ① Setting mark

#### Caution:

Do not turn the pattern selector dial while the needle is in the fabric, otherwise the needle may bend or break.

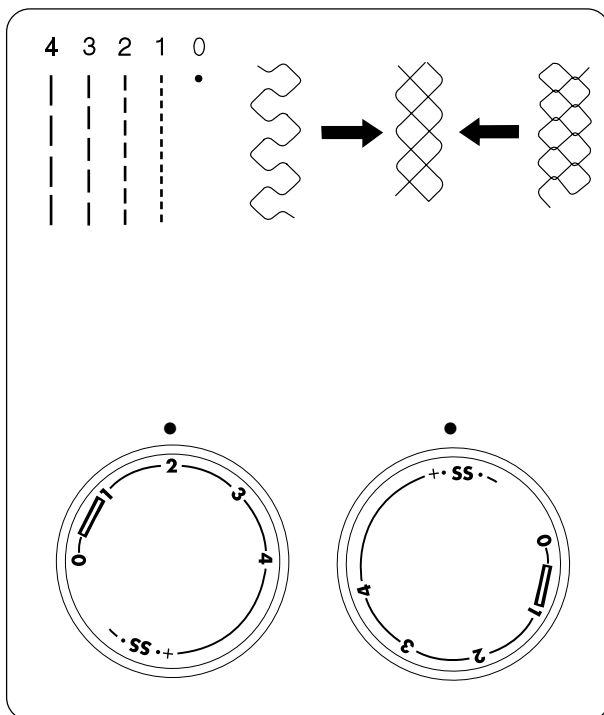

### Stitch Length Dial

Turn the stitch length dial to set the desired stitch length at the setting mark.

The higher the number, the longer the stitch length

- ① Setting mark

“” is the recommended setting for buttonhole stitching.

Adjust the dial in the 0.5–4 range when you sew the zigzag stitch.

Set the dial at “S.S.” to sew the stretch stitch pattern.

If the stretch stitch pattern is not even, turn the stitch length dial in the direction of “-” to compress it, or “+” to expand it.

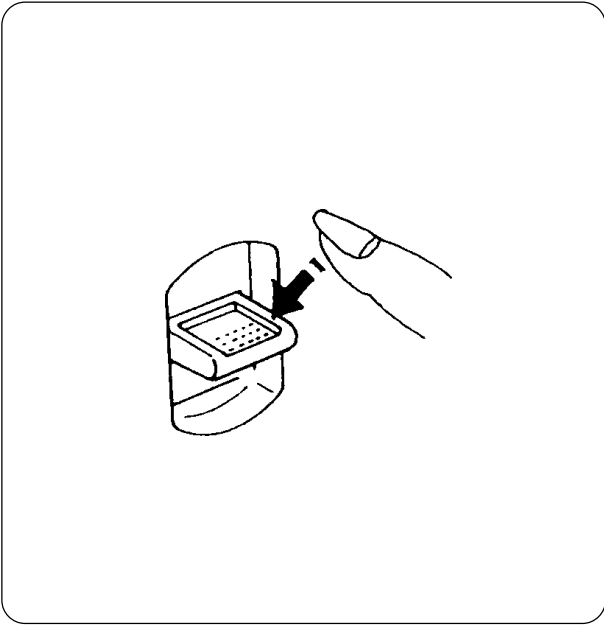

### Reverse Stitch Button

As long as you keep the reverse stitch button depressed, the machines sew in backwards.

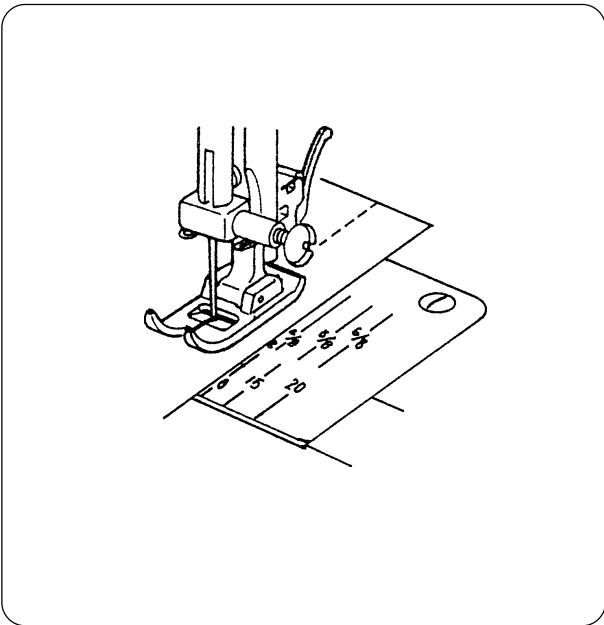

### Seam Guide Line

The seam guides on the needle plate help you to measure seam width.

\* The numbers indicate the distance between the center needle position and the guide line.

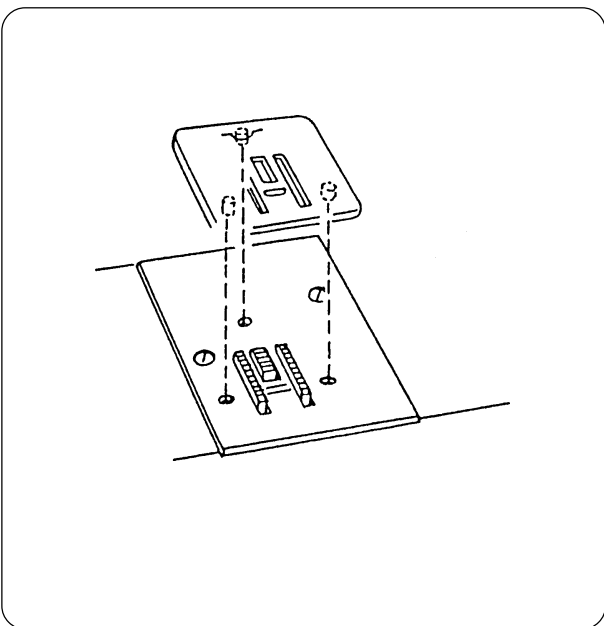

### Darning Plate

To set the darning plate:

Position the darning plate with the 3 pins on the bottom.

Fit the darning plate pins into the needle plate holes. The feed dogs will show through the darning plate holes.

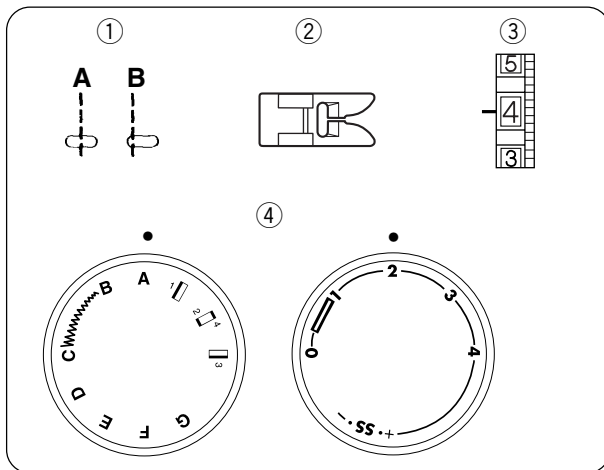

## SECTION 3. BASIC SEWING

### Straight Stitch Sewing

- ① Pattern selector: A or B
- ② Presser foot: Zigzag foot
- ③ Thread tension: 2-6
- ④ Stitch length: 1.5-4

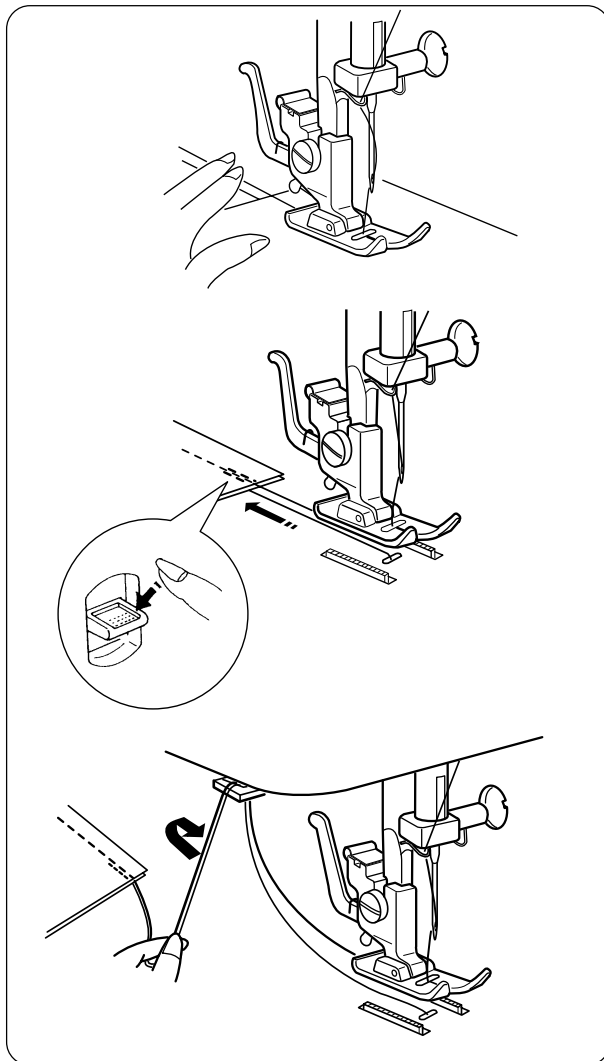

Raise the presser foot and position the fabric with its edge lining up with a seam guide line on the needle plate.

Lower the needle into the fabric.

Lower the presser foot and smooth the threads toward the back. Depress the foot control.

Gently guide the fabric along the guide line letting the fabric feed by itself.

For fastening the end of seams, press the reverse stitch button and sew several reverse stitches.

Raise the presser foot and remove the fabric, drawing the threads to the back.

Draw the threads up and into the thread cutter.

The threads are cut the proper length for starting the next seam.

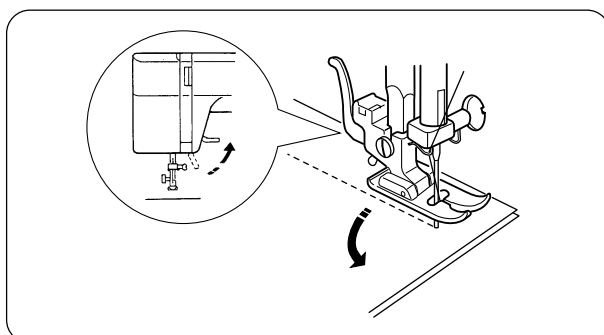

### To change the direction

Stop the machine and turn the balance wheel toward you to bring the needle down into the fabric.

Raise the presser foot.

Pivot the fabric around the needle to change sewing direction as desired.

Lower the presser foot and continue sewing.

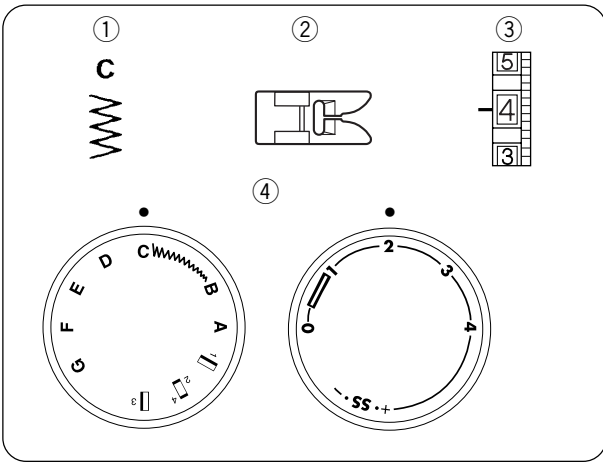

## Zigzag Stitching

- ① Pattern selector: C
- ② Presser foot: Zigzag foot
- ③ Thread tension: 2-5
- ④ Stitch length: 0.5-4

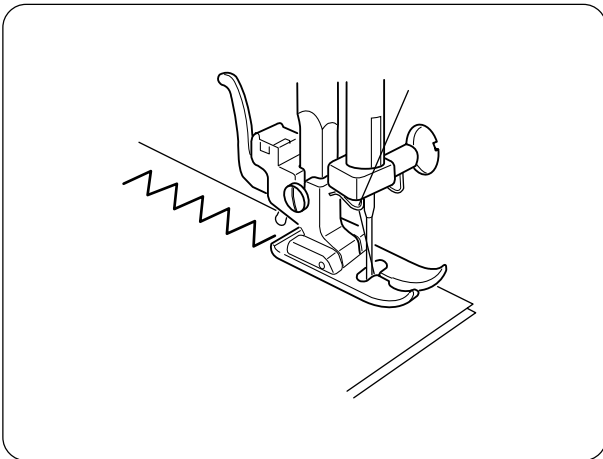

Simple zigzag stitching is widely used for overcasting, sewing on buttons, etc.

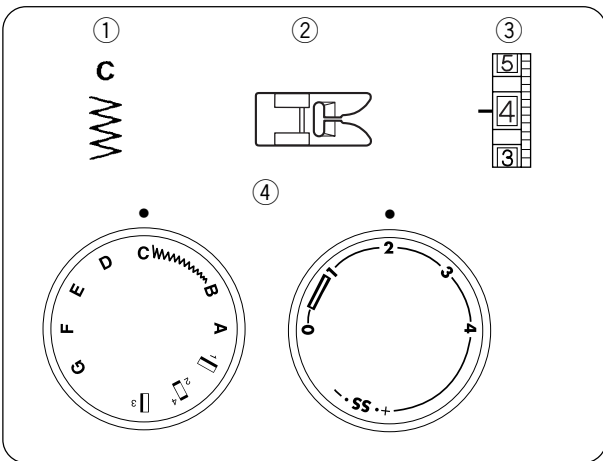

## SECTION 4. UTILITY STITCHING

### Overcasting

- ① Pattern selector: C
- ② Presser foot: Zigzag foot
- ③ Thread tension: 1-4
- ④ Stitch length: 1-2

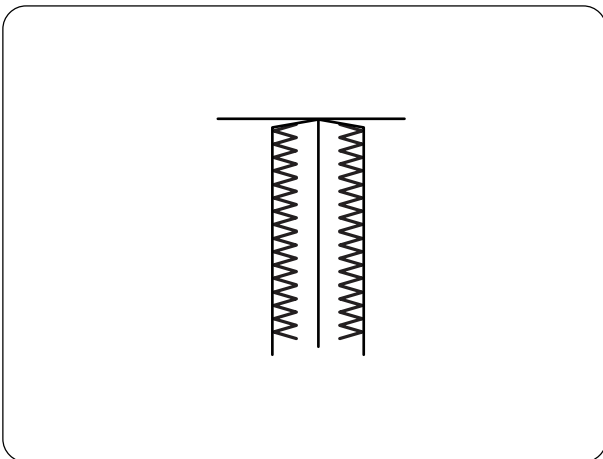

This type of stitch is used on the seam allowance to prevent fabrics from fraying at raw edges.



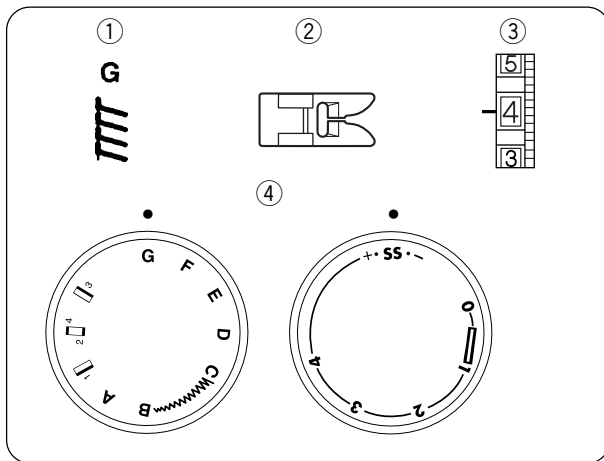

## Overedge Stitching

- ① Pattern selector: G
- ② Presser foot: Zigzag foot
- ③ Thread tension: 1-4
- ④ Stitch length: S.S.

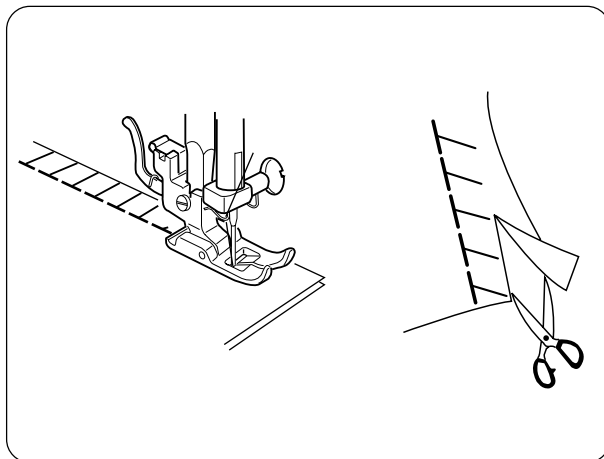

This Overedge stitch is ideal for sewing swimwear and stretch velour because it provides the greatest amount of elasticity and strength.

Overedge stitch will be done most successfully when the right side stitches of zigzag fall slightly off the edge of the fabric.

Place your fabric to allow a 1.6 cm (5/8") seam. Trim the seam allowance after sewing.

**Note :** Be careful not to cut the stitches.

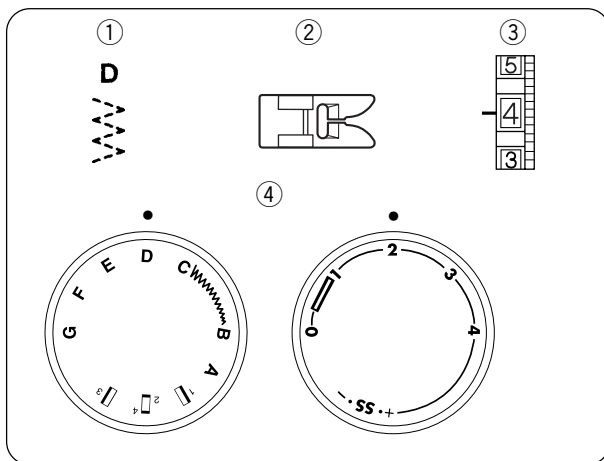

## Tricot Stitch

- ① Pattern selector: D
- ② Presser foot: Zigzag foot
- ③ Thread tension: 1-4
- ④ Stitch length: 0.5-4

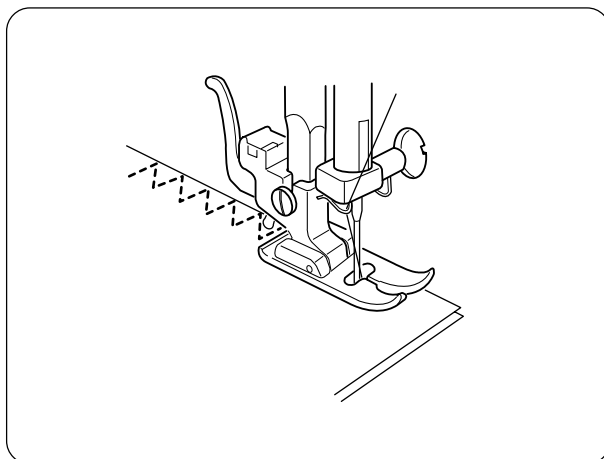

Place the fabric under the presser foot so that the edge is just inside the right edge of the presser foot.

Guide the work so the right hand stitches fall off the edge of the fabric.

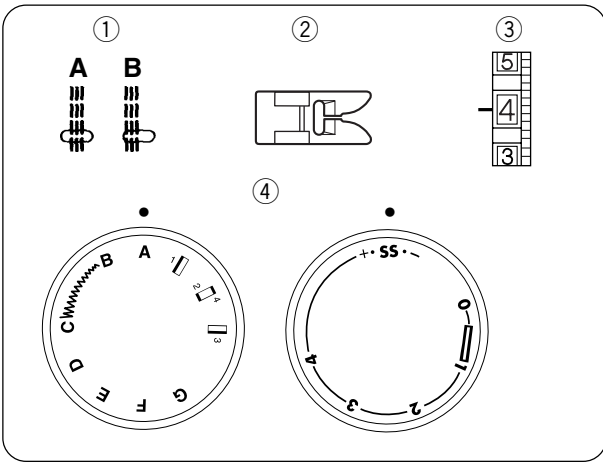

## Triple Stitch

- ① Pattern selector: A or B
- ② Presser foot: Zigzag foot
- ③ Thread tension: 2-6
- ④ Stitch length: S.S.

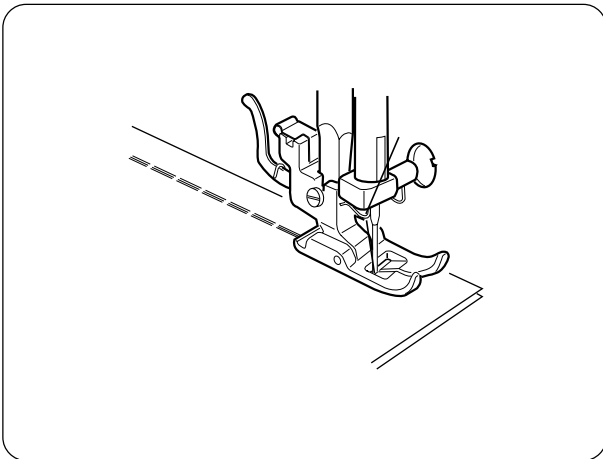

The stitch is sewn with two stitches forward and one stitch backward forming a seam that does not rip easily.

Garments should be basted for fitting before seaming.

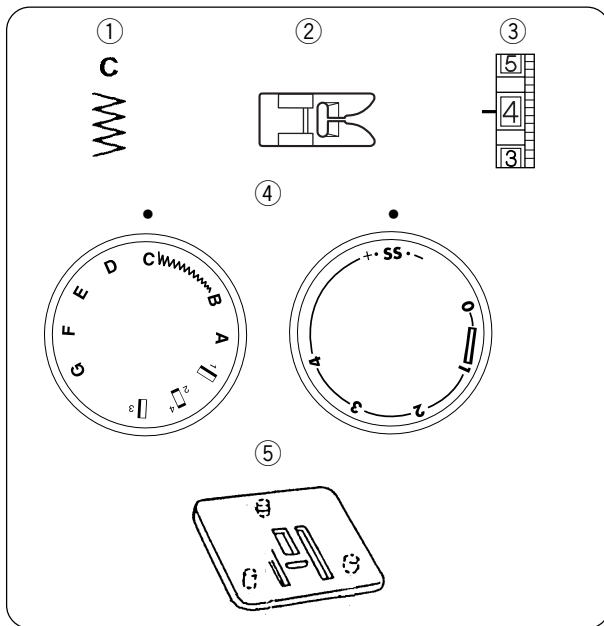

## Sewing Buttons

- ① Pattern selector: C
- ② Presser foot: Zigzag foot
- ③ Thread tension: 1-3
- ④ Stitch length: Any
- ⑤ Darning plate

Use the darning plate for button sewing. (see page 12.)

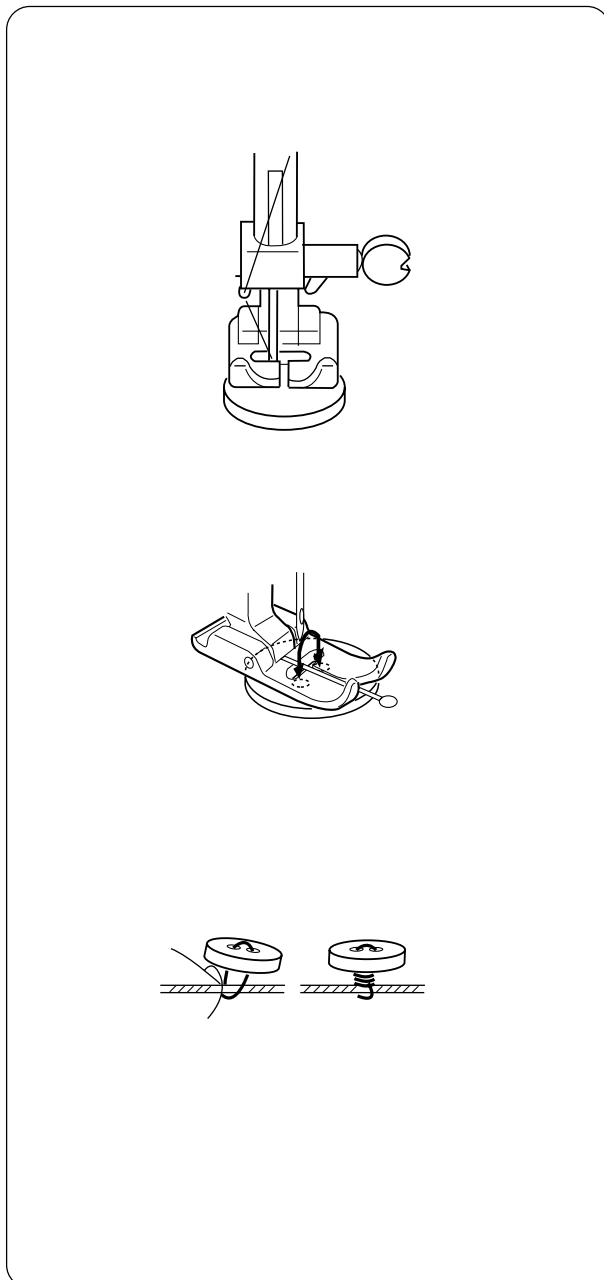

Set the Pattern Selector at **B** (left needle position). Mark the button placements on the fabric. Position the darning plate onto the needle plate. Place fabric under the foot. Place the button under the foot aligning the left hole with the needle point. Lower the foot. Sew a few stitches to lock the threads. Place a straight pin on top of the button in between the holes. (See illustration) When sewing over the button and straight pin, a shank will be created.

Set the Pattern Selector at **C**. Select the zigzag width to match the holes in the button. Turn the balance wheel to confirm correct width. Sew several stitches to secure the button to the fabric. Set the Pattern Selector at **B**. Sew several stitches to lock the threads. Cut the threads 20 cm (8") leaving a thread tail.

Bring the needle thread down through the button hole and wind it around the thread shank. Draw the thread to the wrong side and knot.

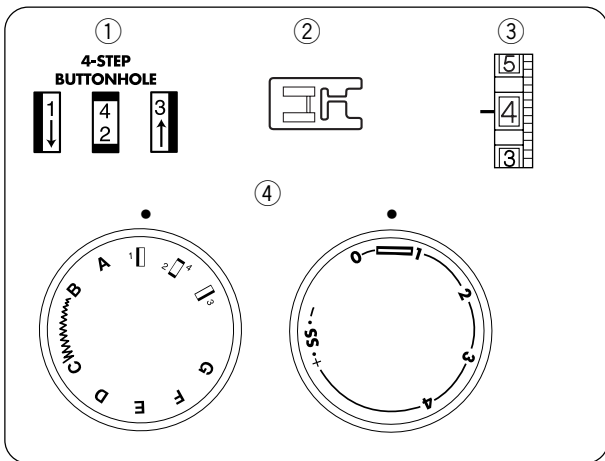

## Buttonhole

- ① Pattern selector: Buttonhole foot
- ② Presser foot: Buttonhole foot
- ③ Thread tension: 1–5
- ④ Stitch length: 0.25–1

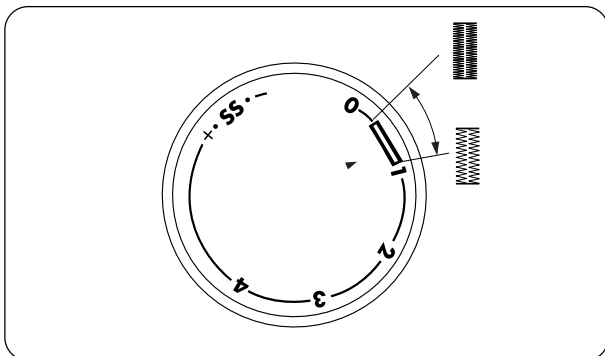

### To adjust buttonhole stitch density:

Set the stitch length dial between 0.5 and 1.0 to adjust the buttonhole stitch density.

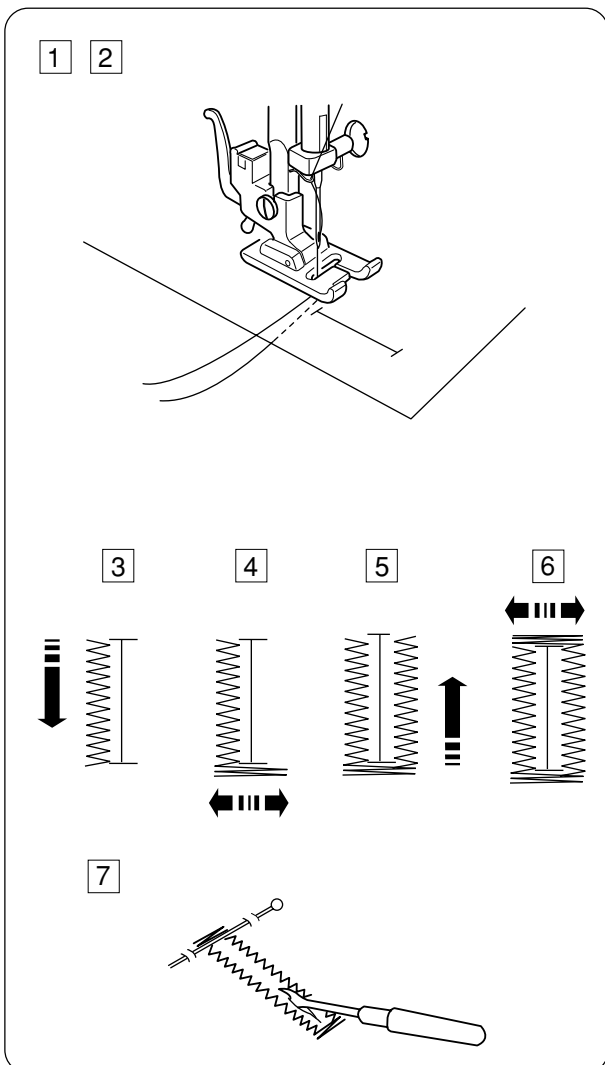

- 1 Carefully mark buttonhole length on fabric. Place the fabric under the foot with the button hole marking running toward you.
- 2 Slide both threads to the left. Line up the foot with the top mark on the fabric. Lower the needle into the garment where the buttonhole is to start, and lower the foot.
- 3 Set the pattern selector dial at “ 1 ”. Sew forward until you reach the front marking of your buttonhole. Stop sewing at a left stitch.
- 4 Set the pattern selector dial at “ 4 ”. Sew 5 stitches. Stop sewing at a right stitch.
- 5 Set the pattern selector dial at “ 3 ”. Sew until you reach the back marking of the buttonhole. Stop sewing at a right stitch.
- 6 Set the pattern selector dial at “ 4 ”. Sew a few bartacks and raise the needle from the fabric. Set the stitch length dial to “0” and the pattern selector dial at straight sewing. Sew a few locking stitches.
- 7 Remove the fabric from the machine and cut the sewing thread. Insert a pin inside the bartack. Then cut the opening with a seam ripper. Take care not to cut the stitches.

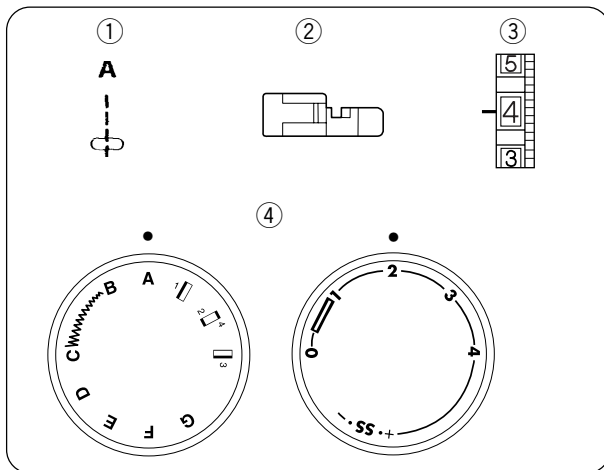

## Zipper Application

- ① Pattern selector: A
- ② Presser foot: Zipper foot
- ③ Thread tension: 3–6
- ④ Stitch length: 2

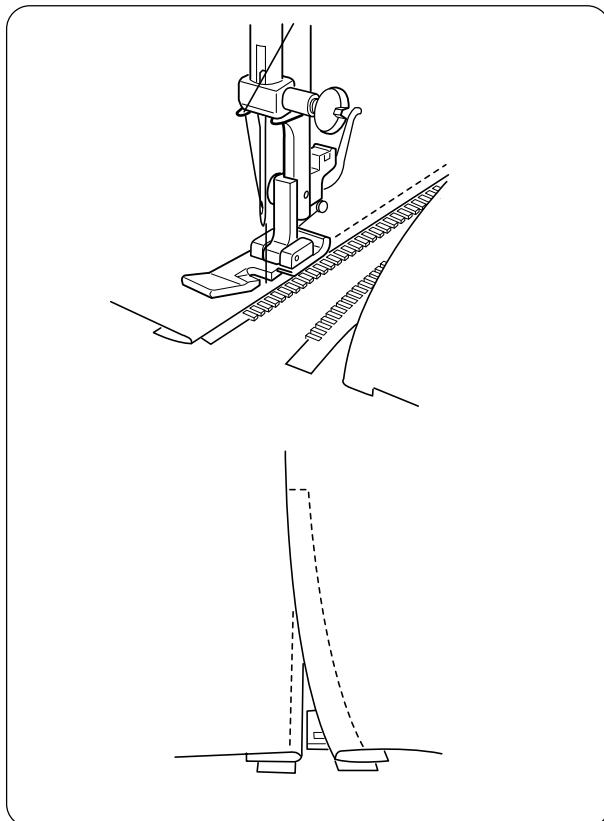

Pin or baste zipper tape to fabric and place it under the foot.

Smooth the threads toward the back and lower the foot.

To sew the left side of the zipper, guide the zipper teeth along the edge of the foot and stitch through the garment and zipper tape.

Turn the fabric and sew the other side of the zipper in the same way as you did the left side.

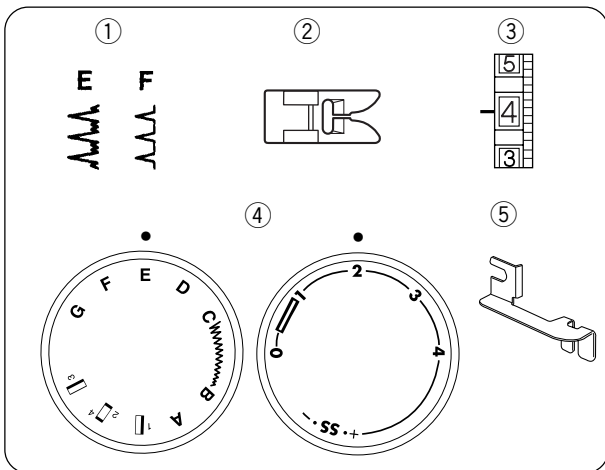

## Blind Hem Stitch

- ① Pattern selector: E or F
- ② Presser foot: Zigzag foot
- ③ Thread tension: 2-4
- ④ Stitch length: 1-3
- ⑤ Hem guide

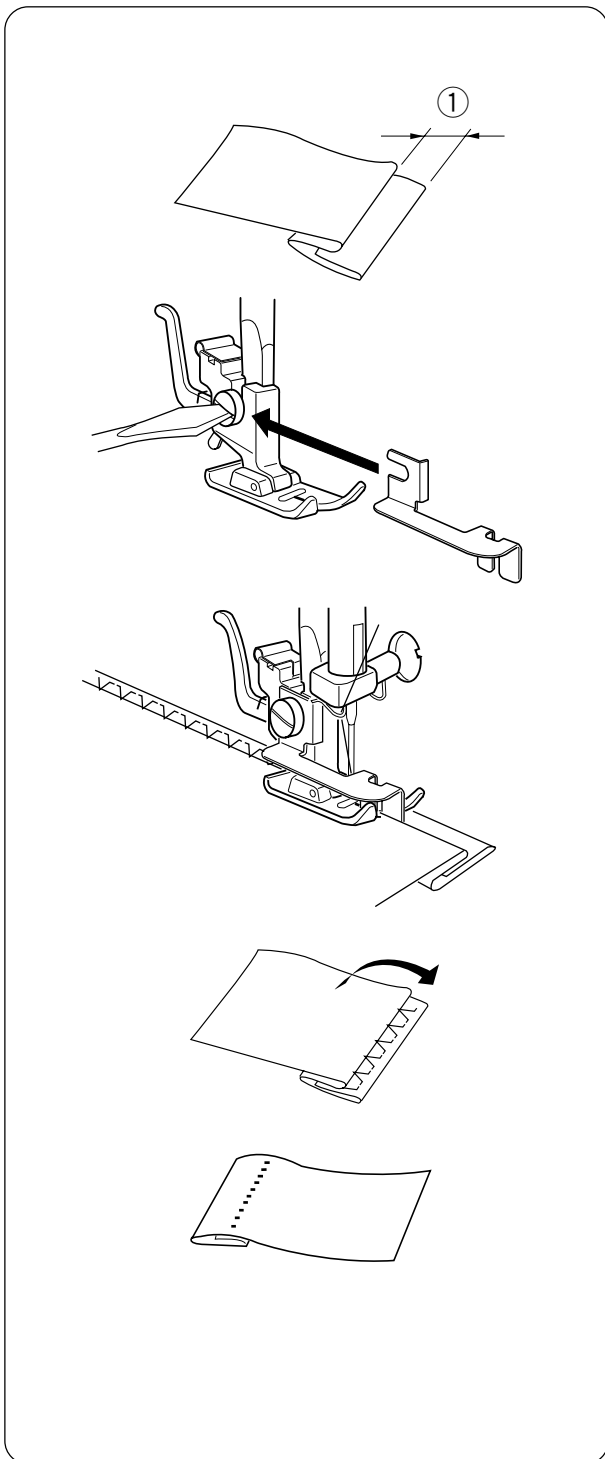

Fold up the fabric as illustrated.

Lower the presser foot, then loosen the foot holder screw to place the hem guide between the screw and the shank of foot holder.

Tighten the screw making sure the wall of hem guide is placed in the middle of the toes of the presser foot.

① 0.4 - 0.7cm (3/16" - 5/16")

Raise the presser foot and place the fabric under the foot so that the fold rests against the wall of hem guide.

Lower the foot, then stitch slowly for better control so that the zigzag stitches fall on the hem allowance and pierce the fold.

While sewing, make sure the fold runs along the wall of hem guide.

Spread the fabric flat with the right side facing up.

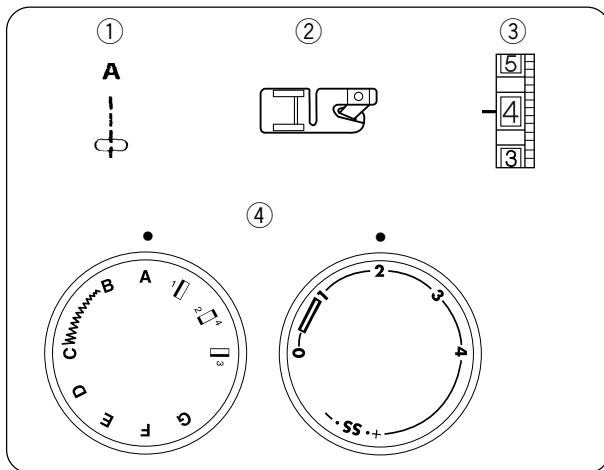

## Rolled Hem

- ① Pattern selector: A
- ② Presser foot: Hemmer foot
- ③ Thread tension: 2-6
- ④ Stitch length: 1.5-4

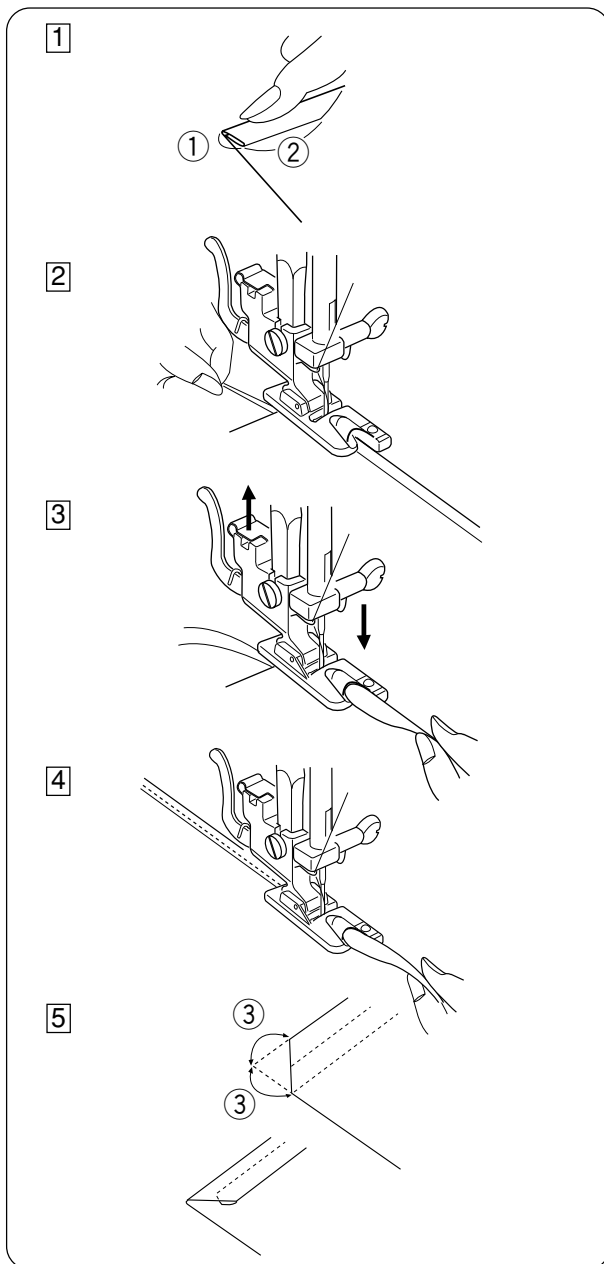

- ① Make a double 0.25cm (1/8") fold approximately 8cm (3") in length.

- ① 0.25cm (1/8")
- ② 8cm (3")

- ② Lower the needle into the fabric at the point where sewing is to begin, then lower the hemmer foot.

Sew three or four stitches while holding the needle and bobbin threads.

- ③ Lower the needle into the fabric and lift the hemmer foot. Insert the folded portion of the fabric into the curl of the hemmer foot.

- ④ Lower the hemmer foot, then sew by lifting up the edge of the fabric to keep it feeding smoothly and evenly.

- ⑤ Trim about 0.7cm (5/16") from corners as illustrated, to reduce bulk.

- ③ 0.7cm (5/16")

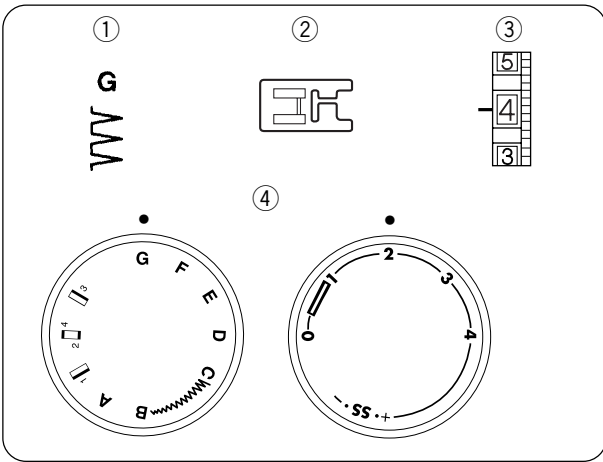

### Shell Tuck

- ① Pattern selector: G
- ② Presser foot: Buttonhole foot
- ③ Thread tension: 6–9
- ④ Stitch length: 2–3

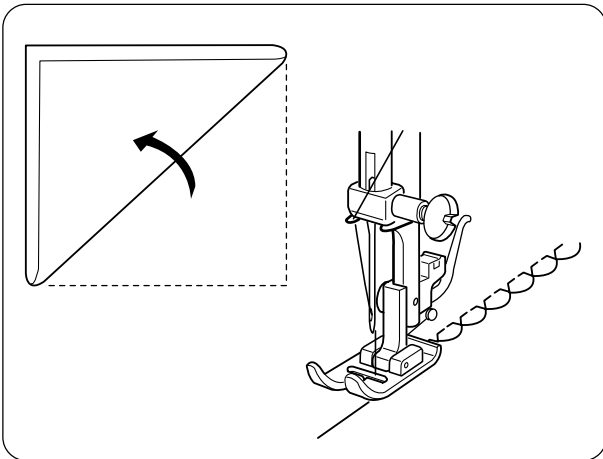

Place the folded edge along the slot of foot. The needle should fall off the edge of the fabric on the right forming a tuck.

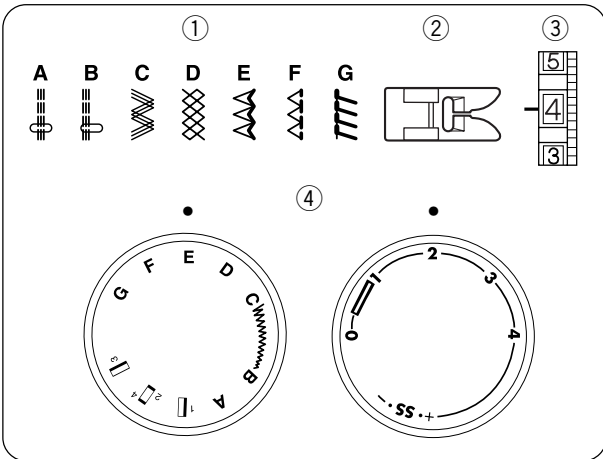

### Stretch Stitch Patterns

- ① Pattern selector: A–G
- ② Presser foot: Zigzag foot
- ③ Thread tension: 1–4
- ④ Stitch length: S.S.

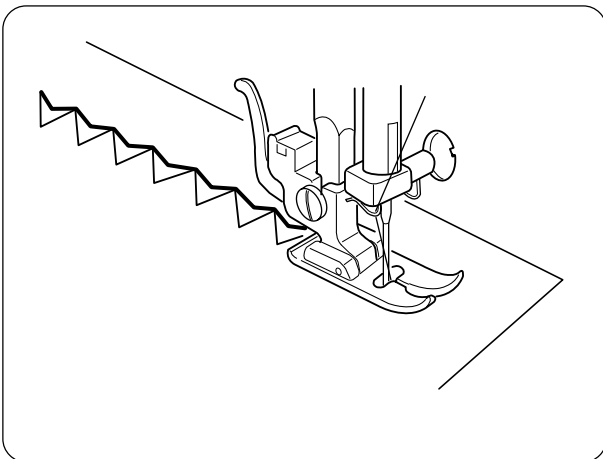

If forward and reverse feeds become unbalanced due to the type of fabric, restore the balance by turning the stitch length dial as follows:

If patterns are compressed, turn the dial toward “+”.

If patterns are drawn out, turn the dial toward “-”. (See Page 11.)



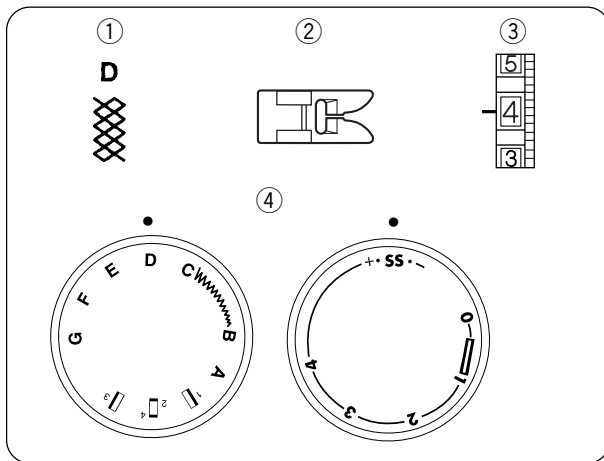

## Smocking

- ① Pattern selector: D
- ② Presser foot: Zigzag foot
- ③ Thread tension: 1-4
- ④ Stitch length: S.S.

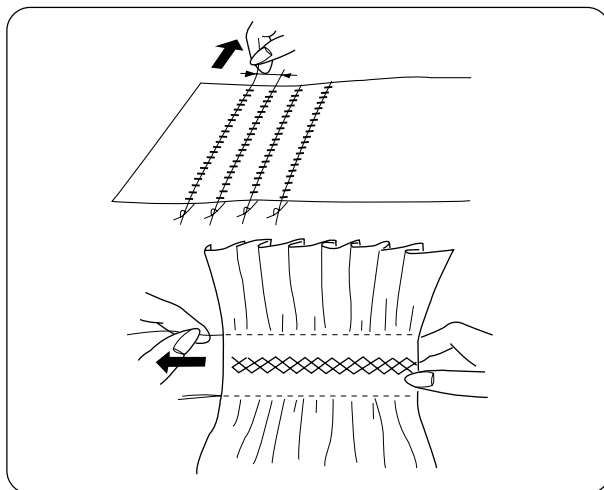

With the stitch length at “4”, sew straight stitching lines 1 cm (3/8”) apart, across the area to be smocked.

Knot the threads along one edge. Pull the bobbin threads and distribute the gathers evenly.

Secure the threads at the other end.

Sew the decorative stitch between the gathering stitches.

Pull out the gathering stitches.

**Note:** Loosen the needle thread tension to make gathering easier.

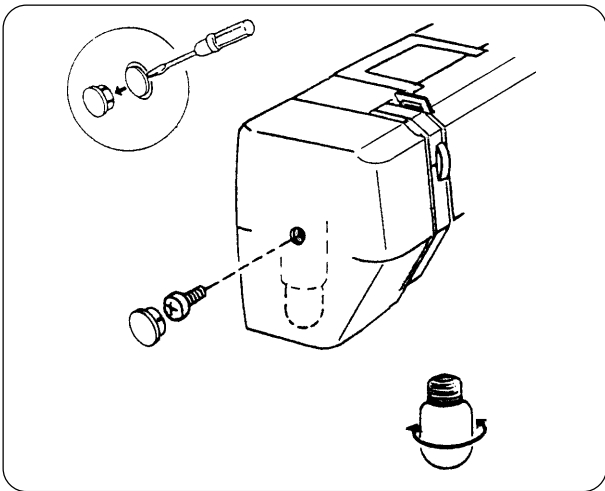

## SECTION 5. CARE OF YOUR MACHINE

### Sewing Light

The sewing light is located behind the face plate. To change the bulb, take the face plate off the sewing machine by removing the set screw.

- Unplug the power supply before changing the bulb.
- To remove, turn the bulb to the left.
- To attach, turn the bulb to the right.

Warning: The bulb could be HOT. Protect your fingers when handle it.

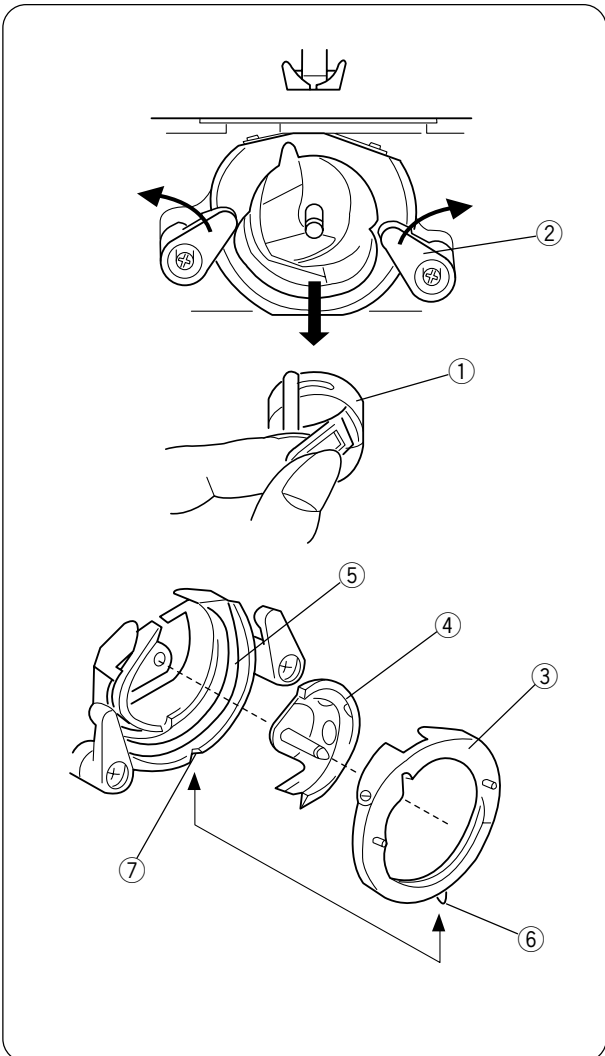

### Dismantling and Assembling

#### Shuttle Race Unit

**Note :** Turn off the power switch and/or unplug the machine.

##### To dismantle shuttle race unit:

Raise the needle to its highest position and open the hook cover.

Open the hinged latch of bobbin case and take it out of the machine.

Open the hook race ring holders and remove the shuttle race ring.

Remove the hook.

\* Clean the hook race with a brush and a soft dry cloth.

- ① Bobbin case
- ② Shuttle race ring holder
- ③ Shuttle race ring
- ④ Shuttle
- ⑤ Shuttle race

##### To assemble shuttle race unit:

Shuttle the hook by the center pin and fit it carefully back into the shuttle race, forming a perfect circle with the shuttle driver.

Attach the shuttle race ring making sure the bottom pin fits into the notch.

Lock the shuttle race ring by turning the holders back into position. Insert the bobbin case.

- ⑥ Pin
- ⑦ Notch

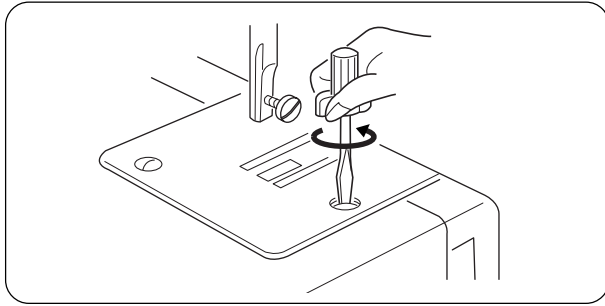

### Cleaning the Feed Dog

**Note :** Turn off the power switch and/or unplug the machine before cleaning the feed dog.

Remove the needle and the presser foot.  
Remove the needle plate set screw and remove the needle plate.

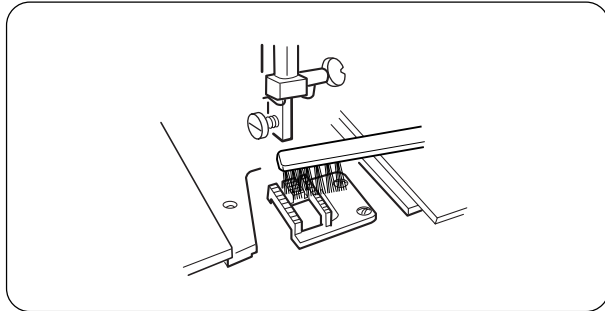

With a brush, clean out dust and lint clogging the feed dog teeth.  
Reset the needle plate.

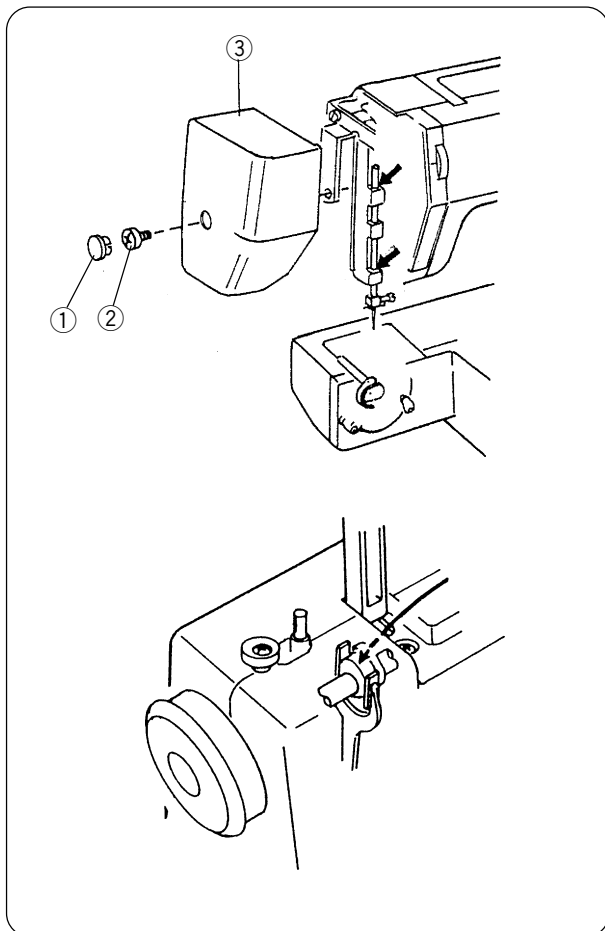

### Oiling the Machine

Remove the cap, screw and face plate.

Apply a few drops of fine quality sewing machine oil to the points indicated by the arrows in the figures.

For a machine in constant use, oil two or three times a year.

If the machine has stood idle for some time and does not work smoothly, apply a few drops of kerosene at the oiling points, and run the machine rapidly for one minute.

**Note:** Before oiling, wipe off the oiling points.  
Turn off the power switch when oiling the machine.

- ① Cap
- ② Screw
- ③ Face plate

## Troubleshooting

Condition	Cause	Reference
<b>The needle thread breaks.</b>	<ol style="list-style-type: none"> <li>1. The needle thread is not threaded properly.</li> <li>2. The needle thread tension is too tight.</li> <li>3. The needle is bent or blunt.</li> <li>4. The needle is incorrectly inserted.</li> <li>5. The fabric is not being drawn to the back when sewing is finished.</li> <li>6. The thread is either too heavy or too fine for the needle.</li> </ol>	<p>See Page 8 See Page 10 See Page 5 See Page 5 See Page 13 See Page 5</p>
<b>The bobbin thread breaks.</b>	<ol style="list-style-type: none"> <li>1. The bobbin thread is not threaded properly in the bobbin case.</li> <li>2. Lint has collected in the bobbin case.</li> <li>3. The bobbin is damaged and doesn't turn smoothly.</li> </ol>	<p>See Page 7 Clean the bobbin case. Replace bobbin.</p>
<b>The needle breaks.</b>	<ol style="list-style-type: none"> <li>1. The needle is incorrectly inserted.</li> <li>2. The needle is bent or blunt.</li> <li>3. The needle clamp screw is loose.</li> <li>4. The tension of the needle thread is too tight.</li> <li>5. The fabric is not drawn to the back when sewing is finished.</li> <li>6. The needle is too fine for the fabric being sewn.</li> <li>7. The pattern selector dial had been turned while the needle was in the material.</li> </ol>	<p>See Page 5 See Page 5 See Page 5 See Page 8 See Page 13 See Page 5 See Page 11</p>
<b>Skipped stitches</b>	<ol style="list-style-type: none"> <li>1. The needle is incorrectly inserted.</li> <li>2. The needle is bent or blunt.</li> <li>3. The needle and/or threads are not suitable for the work being sewn.</li> <li>4. A BLUE TIPPED needle is not being used for sewing stretch, very fine fabrics and synthetics.</li> <li>5. The needle thread is not threaded properly.</li> </ol>	<p>See Page 5 See Page 5 See Page 5 See Page 5 See Page 8</p>
<b>Seam puckering</b>	<ol style="list-style-type: none"> <li>1. The needle thread tension is too tight.</li> <li>2. The machine is not threaded correctly.</li> <li>3. The needle is too heavy for the fabric being sewn.</li> <li>4. The stitches are too coarse for the fabric being new line sewn.</li> </ol> <p>* When sewing extremely light weight materials, place a sheet of paper underneath the fabric.</p>	<p>See Page 10 See Page 8 See Page 5 Make the stitches denser.</p>
<b>Stitches form loops below the work</b>	<ol style="list-style-type: none"> <li>1. The needle thread tension is too loose.</li> <li>2. The needle is either too heavy or too fine for the thread.</li> </ol>	<p>See Page 8 See Page 5</p>
<b>The cloth is not feeding smoothly.</b>	<ol style="list-style-type: none"> <li>1. The feed dog is packed with lint.</li> <li>2. The stitches are too fine.</li> </ol>	<p>See Page 25 Make the stitches coarser.</p>
<b>The machine does not work.</b>	<ol style="list-style-type: none"> <li>1. The machine is not plugged in.</li> <li>2. Thread is caught in the hook race.</li> <li>3. Handwheel has been disengaged for bobbin winding.</li> </ol>	<p>See Page 4 See Page 25 See Page 7</p>
<b>The machine does not run smoothly and is noisy.</b>	<ol style="list-style-type: none"> <li>1. Threads have been caught in hook mechanism.</li> <li>2. The feed dog is packed with lint.</li> </ol>	<p>See Page 25 See Page 25</p>

